



A GUIDE TO BUYING A PRE-LOVED ACOUSTIC PIANO

There are many reasons you may want to buy a second hand or pre-loved piano. It could be that you want a particular make, brand or model that is no longer made or that you can't afford to buy brand new. An older style of piano may suit the rest of the furniture in your house or you may have been offered a family heirloom and are wondering about its condition and value.



A “modern” piano is essentially a 20th Century instrument, which few know very much about. Even music teachers and experienced players often know little about piano construction or the rapidly changing state of piano manufacturing. They often rely on their past experience with certain brands, most of which have changed significantly.



Sadly, pianos are not like violins that improve with age and, unless they are regularly maintained, they can lose quality of sound and playing action. Prices can vary widely and, unlike other consumer items where you can compare features for a gauge of value, most pianos regardless of price look very similar and do pretty much the same thing. All of this can lead to a paralysis in decision making or a decision based on the “look” rather than the “quality” of the instrument.

This guide is designed to help you ask the right questions and look for key clues to gauge the quality and value of the instrument.

Questions to Ask

Has the piano been regularly tuned and maintained?

Pianos generally require tuning at least once a year. If the piano has not been tuned for up to 5 years, in most cases it will still be able to be tuned. However, it may require 2 or 3 tunings, spaced a week apart to raise it to A-440 pitch. (A-440 is the accepted pitch standard used when tuning instruments in Western countries.) If not maintained with regular tuning, there may also be mechanical repairs to complete. Raising the tuning of a piano up to A-440 pitch can cost up to \$500.

What is the make, year of manufacture and history of ownership?

Like purchasing a car, this will give you some idea of the quality of information and some comparison points when making a final decision.

Has the piano been played regularly over its lifetime and by how many people?

A piano played by one student for 5 years could differ greatly in quality over a piano that's been played every day by many students.

Things to Look For

Does the piano have an iron frame?

Over the years, the pitch of pianos has increased, meaning the strings require more tension. Older style pianos with a full iron frame have the structural strength to support this increase in tension. However, pianos with a $\frac{3}{4}$ iron frame or wooden frame are generally unable to be tuned to A-440 pitch.

Does the piano have an underdamper action?

All pianos have a mechanical component that causes the hammer to strike the strings when the keys are depressed, thereby making the sound. Most commonly, pianos will have an underdamper mechanism, meaning that the damper is located underneath the hammer. However, some older style and lesser quality pianos have an action known as an overdamped, where the damper sits above the hammer. A piano that is overdamped is extremely costly to repair and maintain, as parts and tools are almost impossible to find. In some cases, keys on an overdamped piano cannot be repaired, rendering the piano useless. A piano with an underdamper mechanism is more easily and less costly to repair and maintain.

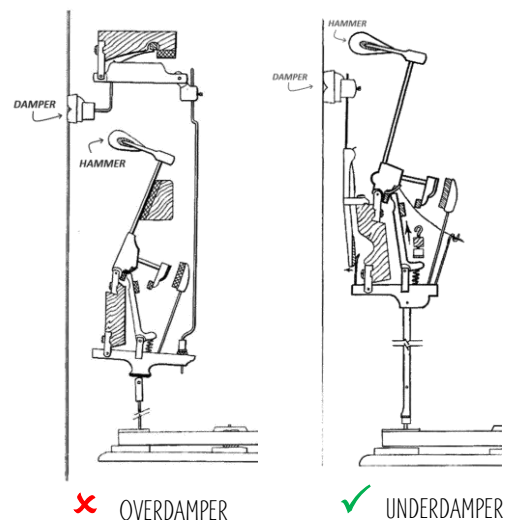

Is the piano overstrung?

Most pianos are overstrung, meaning that the bass strings cross diagonally in front of the treble and mid strings. This allows longer bass strings, giving the piano richer tones, truer bass notes and sturdier construction. Occasionally, you may find a straight strung piano, where the all the strings run parallel to each other on the frame. A straight strung piano generally has inferior tone, especially in the bass, and tends to be less stable. Usually it is best to avoid straight strung pianos.

Is the piano structurally stable?

Whilst most faults on a piano can be corrected, some problems are terminal. Terminal problems that pianos can develop include a cracked frame, cracked soundboard, split bridges or ribs or a weakened pin block. Any of these problems will render the piano useless.

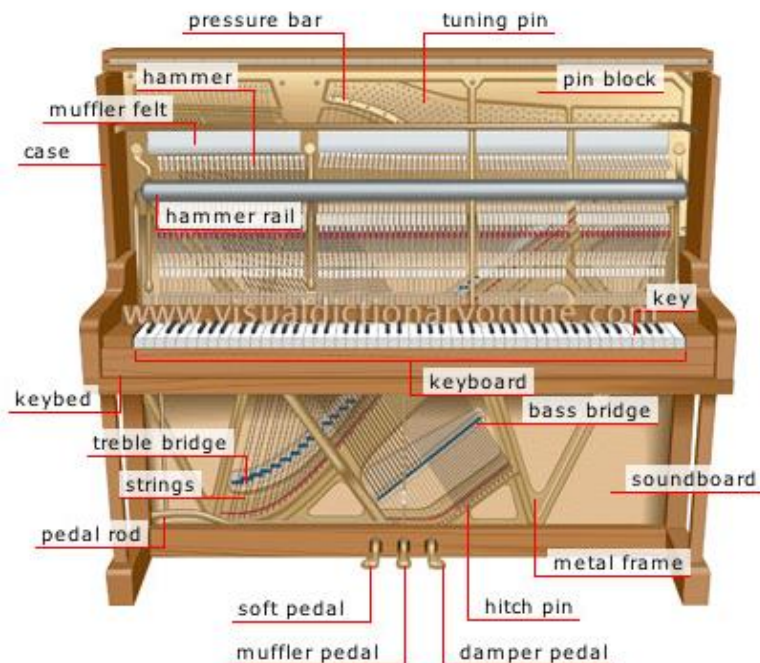

Other Things to Consider

Have you considered the make and model of the piano?

Just like the motor vehicle industry, the make and model of a piano can give an idea not only the quality of the piano but also what the future maintenance costs are likely to be. Some piano manufacturers in the 1980s, 1990s, and even later, began outsourcing aspects of the manufacturing process to factories in China, Korea and Indonesia. As a result, some parts and materials found in these pianos are no longer available, making maintenance, if required, difficult and costly.

Extras to budget for when buying a secondhand piano

Pianos are large, heavy and complicated mechanical instruments. The costs associated with transport and subsequent tuning and repair can often be far more than people envisage. If you are considering purchasing a piano privately for between \$400-\$800, you will need to factor in at least an additional \$500-\$800 for removal costs, tuning and repairs.

Purchasing a reliable piano rewards and encourages those learning piano.

Just like learning to drive a car, a beginner's piano needs to be a reliable instrument. If the piano doesn't 'sound like the one at school' or notes stick or are broken, beginners can become frustrated and give up. Ensure you carefully examine a potential purchase for the major points above and, once transported, get it checked over by a qualified piano technician and tuner to give the player the best possible experience.



***Good luck with this important purchase and if we can help with
removal, tuning, repairs or restoration,
please give us a call on [08 8362 8813](tel:0883628813) or [0408 221 272!](tel:0408221272)***

***We also sell a select range of new and secondhand pianos –
please check out our [website](#) for latest offers.***